

MODEL PAD 70-5  
REGULATED DC POWER SUPPLY  
OPERATION MANUAL

KIKUSUI ELECTRONICS CORPS

# Power Requirements of this Product

Power requirements of this product have been changed and the relevant sections of the Operation Manual should be revised accordingly.

(Revision should be applied to items indicated by a check mark )

Input voltage

The input voltage of this product is \_\_\_\_\_ VAC,  
and the voltage range is \_\_\_\_\_ to \_\_\_\_\_ VAC. Use the product within this range only.

Input fuse

The rating of this product's input fuse is \_\_\_\_\_ A, \_\_\_\_\_ VAC, and \_\_\_\_\_.

### WARNING

- To avoid electrical shock, always disconnect the AC power cable or turn off the switch on the switchboard before attempting to check or replace the fuse.
- Use a fuse element having a shape, rating, and characteristics suitable for this product. The use of a fuse with a different rating or one that short circuits the fuse holder may result in fire, electric shock, or irreparable damage.

AC power cable

The product is provided with AC power cables described below. If the cable has no power plug, attach a power plug or crimp-style terminals to the cable in accordance with the wire colors specified in the drawing.

### WARNING

- The attachment of a power plug or crimp-style terminals must be carried out by qualified personnel.



# C O N T E N T S

	Page
1. INTRODUCTION .....	1
2. SPECIFICATION .....	2
3. OPERATION .....	5
3.1 Front Panel Description .....	5
3.2 Precaution .....	7
3.3 How to use sampling terminals .....	7
3.4 Constant-voltage, current characteristics .....	9
3.5 Transient response .....	9
3.6 Single operation .....	10
3.7 Series connection .....	11
3.8 Parallel connection .....	13
3.9 One control parallel operation .....	14
3.10 Remote control .....	15
3.11 Internal temperature detector circuit .....	17
.....	1
.....	12
.....	13

\* BLOCK DIAGRAM

## 1. INTRODUCTION

Kikusui Electronics' Model PAD 70-5 is an IC used and all-silicon-transistorized, highly reliable, variable regulated DC power supply which has excellent regulation, a low temperature coefficient and fast transient response.

It is a universal type usable for either a digital or analog circuit. Since a pre-regulated circuit is built-in, overheating of the entire instrument is suppressed. Therefore, the instrument is compact and light-weight in comparison with the conventional instruments although it is of natural cooling type.

The output voltage is adjustable precisely and smoothly over a range of zero to 70V with a 10-turn type variable resistor.

The maximum output current is 5A. Model PAD 70-5 can be used as a constant current power supply over a range of 0.2 to 5A. Use of a new circuit technique permits the constant current characteristic to be improved largely, as compared with the other type.

Model PAD 70-5 is a constant voltage-current automatic crossover type in which the constant output voltage performance and constant current performance are changed over automatically according to load variation.

Two LEDs mounted on the front panel indicate the respective operation modes alternately (constant voltage or constant current).

Model PAD 70-5 is not only used in single operation but in series, parallel or one-control parallel operation by which the voltage or current can be expanded.

Use of an external resistor also permits the output voltage to be remote-controlled.

## 2. SPECIFICATIONS

AC input	----- V AC $\pm 10\%$ , 50/60Hz
Full load	Approximately 800 VA
Dimensions	Case 210W $\times$ 140H $\times$ 410D mm*
Maximum	215W $\times$ 165H $\times$ 453D mm
Weight	Approximately 19 kg
Ambient temperature	0 ~ 40°C
Accessories supplied	Short bar ..... 1
	Fuse 5A ..... 2
	Operation manual ..... 1
Output	
Terminals	On the front panel color coded, aligned horizontally spaced 19mm equally (-, GND, +); the terminal board on the rear panel (-sampling, -, GND, +, +sampling; Obtainable from the front and rear panels.
Polarity	Positive or negative
Floating voltage	$\pm 300V$ maximum
Cooling	Convection
Constant voltage characteristics:	
Voltage	0 ~ 70 V continuously variable with 10-turn variable resistor
Current	5A.
Ripple noise (5 Hz ~ 1 MHz)	1m.V. rms

Voltage regulation (At sampling terminals)	
Line regulation	0.005% + 1mV against $\pm 10\%$ variation of line voltage
Load regulation	0.005% + 2mV against 0 - 100% variation of output current
Transient response (10~100%)	Typical 100 $\mu$ s
Temperature coefficient	Typical 100PPM/ $^{\circ}$ C
Constant current characteristics:	
Voltage	0 ~ 70V continuously variable with 10-turn variable resistor
Current	0.2 ~ 5A; continuously variable
Ripple noise (5 Hz ~ 1 MHz)	1mA rms
Current regulation	
Line regulation	1mA against $\pm 10\%$ variation of line voltage
Load regulation	3mA against 0 ~ 100% variation of output voltage
Operation	Series connection Parallel connection One-control parallel operation Output voltage remote control
Operation mode indication	
LED indication	Constant voltage ..... C. V. Constant current ..... C. C.
Internal temperature detector circuit	When the internal temperature exceeds the rated built-in circuit automatically shunts off the output
Voltmeter	DC 70V accuracy 2.5% of full scale

Ammeter

DC 6A accuracy 2.5% of full scale

- \* Two PAD70-5 can be mounted side by side on a 19" or 500 mm standard rack with rack mounting angle.
- \* Overvoltage protector Model OVP70-10 can be mounted as option.

### 3. OPERATION

#### 3.1 Front Panel Description (See Fig. 3-1)

- |      |                                     |  |
|------|-------------------------------------|--|
| (1)  | POWER switch                        | ON/OFF switch for the input power.<br>Throw it upwards, and the power is on.   |
| (2)  | Pilot lamp                          | Lights when the power is on.   |
| (3)  | Constant voltage<br>indicating lamp | Lights when the constant voltage mode;<br>C. V   |
| (4)  | Constant current<br>indicating lamp | Lights when the constant current mode;<br>C. C   |
| (5)  | VOLTAGE                             | Knob for setting the output voltage.<br>Clockwise rotation increases the output<br>voltage.  |
| (6)  | CURRENT                             | Knob for setting the output current.<br>Clockwise rotation increases the output<br>current.  |
| (7)  | Voltmeter                           | Indicates the output voltage. DC 70 V.   |
| (8)  | Ammeter                             | Indicates the output current. DC 6 A.  |
| (9)  | Output terminals                    | Spaced 19 mm equally and aligned in the<br>following order; from the left, (white),<br>GND (black), +(red).  |
| (10) | Rear terminal plate                 | Output terminals, sampling terminals, GND<br>terminals, remote control terminal and one-<br>control paralalled operation terminals are<br>provided on this terminal board. |
| (11) | Input fuse                          | Inserted in the primary of the power trans-<br>former to avoid possible subsequent faults<br>trouble. Slow blow 15A..  |
| (12) | Output fuse                         | Inserted on the output side to prevent surge<br>current trouble from flowing through the equip-<br>ment connected, and from causing resultant<br>damage. 5A Fuse.          |



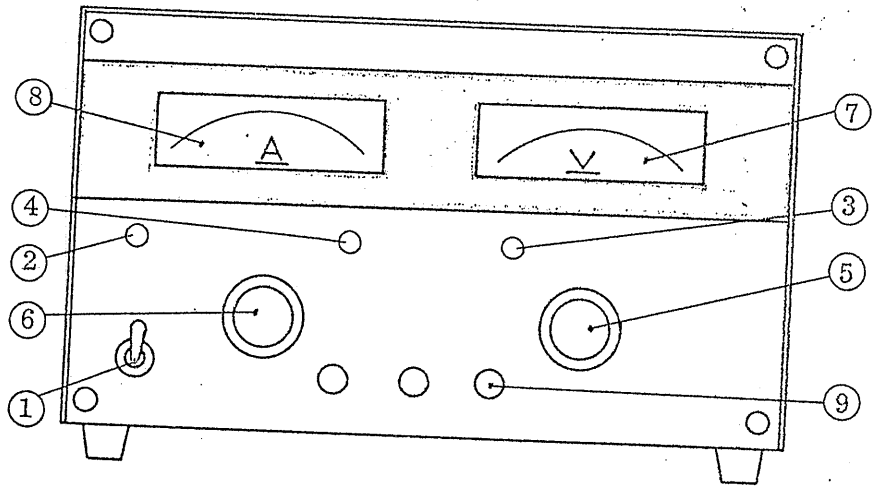

Fig. 3-1 Front Panel

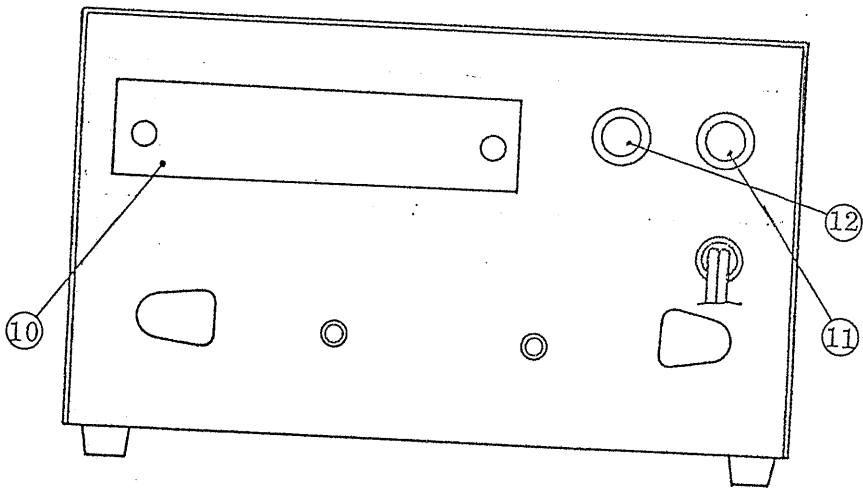

Fig. 3-2. Rear Panel

### 3.2 Precaution

#### AC input

AC input for Model PAD 70-5 should be within a range of

----- V AC  $\pm 10\%$ , 48 ~ 62 Hz.

#### Installation

Avoid using Model PAD 70-5 at a place exposed to heat; where the ambient temperature exceeds a range of zero to 40°C; that is humid or dusty; where it is not be level.

During operation, don't lay Model PAD 70-5 on its side nor put anything on it. Otherwise, a fault may be caused by reduction of its radiation effect.

#### Output voltage overshoot

Voltage between output terminals never exceeds the preset value when the power is turned on or off.

### 3.3 How to use sampling terminals

When Model PAD 70-5 is far from the load, a long lead connecting the output terminals and the load causes load regulation to be deteriorated because of voltage drop due to lead resistance.

The sampling terminals serve to solve this trouble. For the connection diagram, see Fig. 3-3.

1. Remove the jumpers between -S, - and +, and +S terminals on the rear terminal board.
2. Connect the output terminals on the rear or front panel to the load. Connect the sampling terminals and the nearest load terminals with other leads. Match the polarity of the sampling terminals to that of the output terminals.

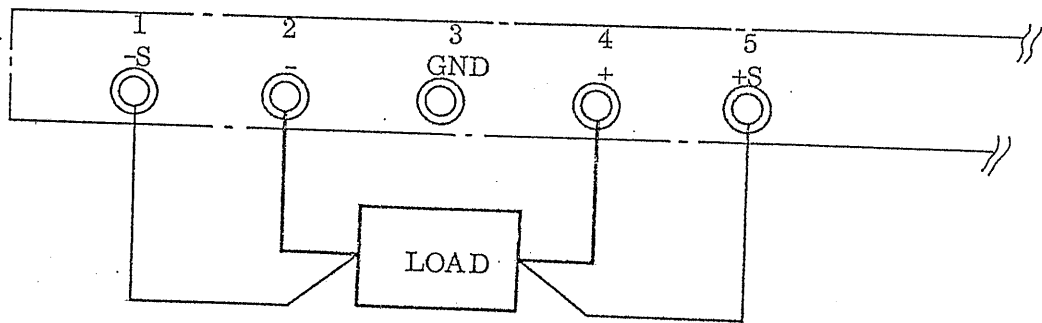

Fig. 3-3

- Note 1 Deterioration of load regulation is calculated by the following formula;
- $$V_d = I_o \times R \text{ (m}\Omega\text{)}$$
- where
- $I_o$  (A) = Load current,  $R$  (m $\Omega$ ) = lead resistance
- $V_d$  = Voltage drop
- Note 2 Use two-conductor shielded wire for sampling to avoid induction causing ripple from outside. Check the sampling leads for proper polarity.
  - No. 3 Be careful since the lead connected to the load affects the preset constant current value due to its resistance.
  - No. 4 As long sampling leads tend to cause oscillation, connect an electrolytic condenser with a capacitance of a few  $\mu$ F's and a dielectric strength of 80V to sampling terminals in the proper polarity.

Note 5 Sampling is impossible if voltage drop of the lead connected to the load is 0.3V or more.

### 3.4 Constant-voltage, current characteristics

The working output characteristic of Model PAD70-5, called constant-voltage/constant-current automatic crossover type, permits continuous transition from constant-current to constant-voltage operation mode in response to the load change.

The intersection of constant-voltage and constant-current operation modes is called crossover point. Fig. 3-4 shows the relationship between this point and the load.

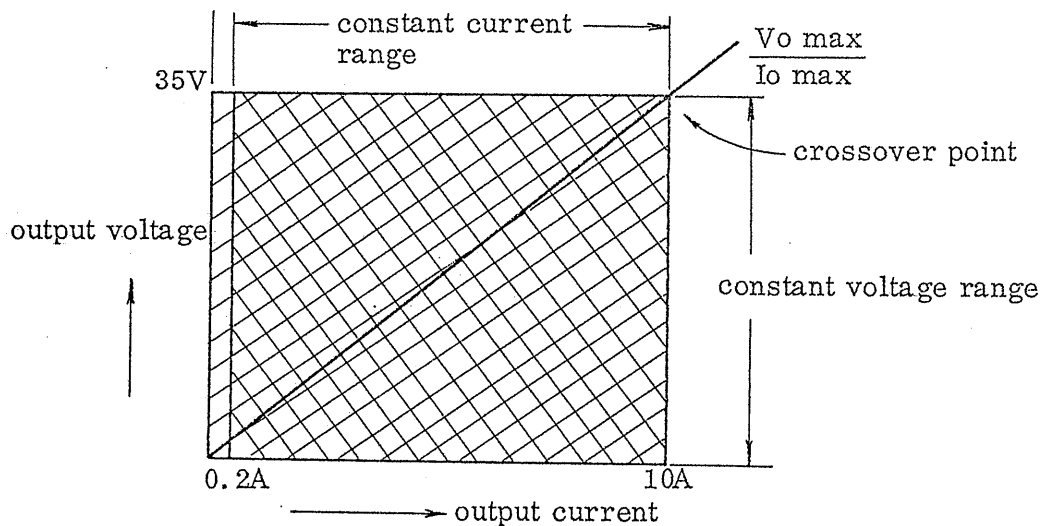

Fig. 3-4

The operation modes of PAD70-5 are indicated by the area with oblique lines.

Operation is possible anywhere within this area.

### 3.5 Transient response

Designed to meet a transient response quickly enough, PAD70-5 can be used for digital or other circuits involving a drastic load variation and in which performance is affected by a transient variation. But this is the characteristic at the output terminals, and if a long lead is extended to the load, then influence of the inductance is not negligible.

In such a case, use capacitors to cancel the inductance.

### 3.6 Single operation

#### Constant voltage performance

- 1) Connect the power cord. Throw the power switch upwards, and Model PAD70-5 is ready to operate immediately, lighting the pilot lamp simultaneously.
- 2) Turn CURRENT knob fully clockwise. Turn VOLTAGE knob until the desired voltage is obtained. (Clockwise rotation increases the output voltage.)
- 3) Connect the output terminals to the load.

Note: When requiring limiting the load current to a certain value. Before the load connect, short the output terminals. Set "CURRENT" knob to the desired current value.

#### Constant current performance

- 1) The same as Paragraph (1) in "Constant voltage performance" above.
- 2) Turn "VOLTAGE" knob clockwise until stop.  
(This implies the maximum output voltage.)
- 3) Short the output terminals. Turn "CURRENT" knob until the desired current value is obtained. (Clockwise rotation increases the output current.)
- 4) The same as Paragraph 3 in "Constant voltage performance" above.

Note 1 Model PAD 70-5 is a constant voltage-current automatic crossover type. When the load current is smaller, the constant current mode is changed over to the constant voltage mode at a specific voltage. Thus, when requiring limiting the output voltage to a certain value, preset the output voltage to the desired value.

Note 2 The constant voltage or constant current mode is indicated by the respective lamps on the front panel alternately.

Constant current mode lamp ..... C,C

Constant voltage mode lamp ..... C,V

Note 3 For use of the sampling terminals, see Note 3 in Chapter 3.4 "How to use sampling terminals".

### 3.7 Series connection

A higher output voltage than 70 V can be obtained by connecting two Model PAD 70-5s in series.

Note 1 Be careful not to ground the positive terminal of one Model PAD 70-5 when grounding the negative terminal of the other in Fig. 3-5.

Note 2 The voltage at each output terminal should not exceed the floating voltage.

Note 3 Avoid the series connection with other model.

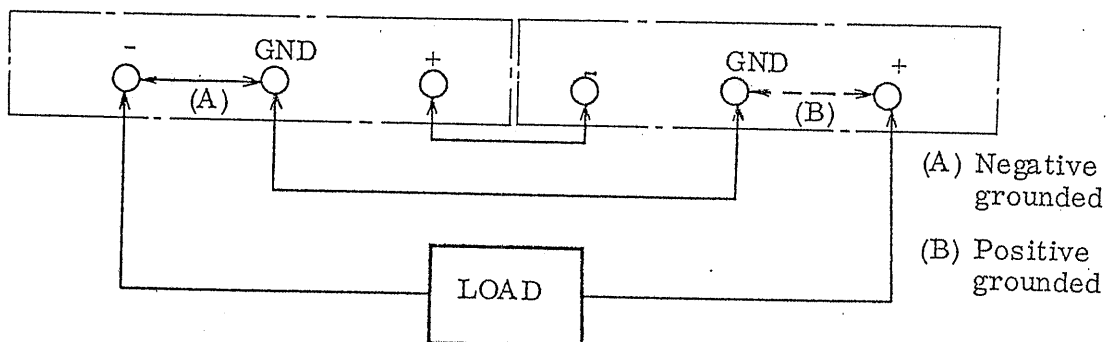

Fig. 3-5 Series connection diagram

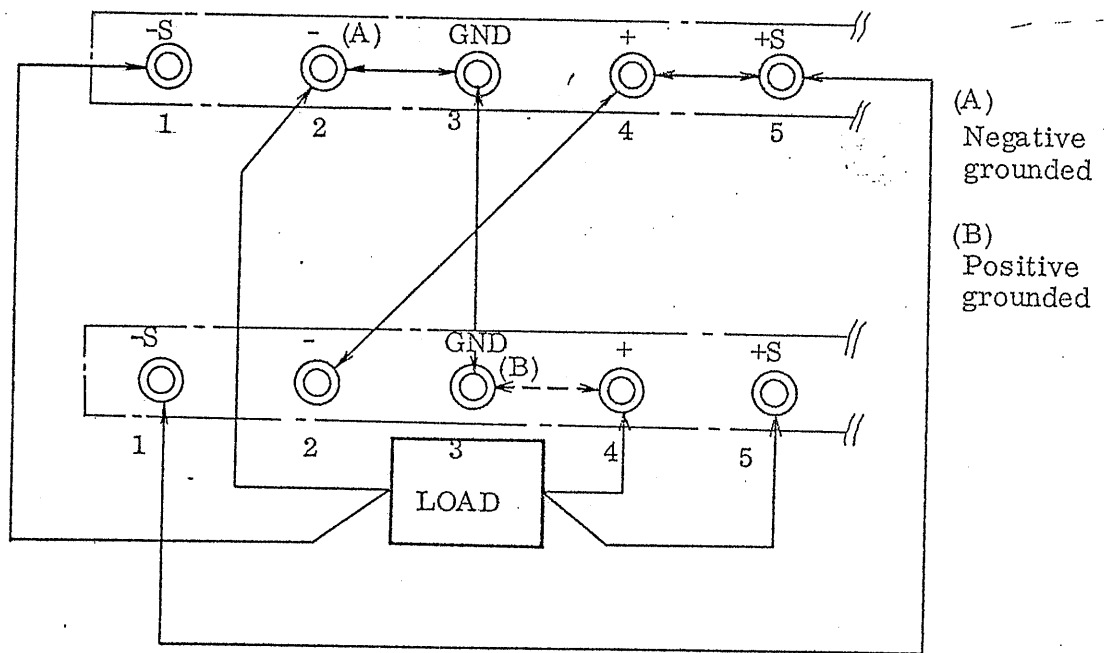

Fig. 3-6 Sampling terminal connection diagram in series connection

When two Model PAD 70-5 connected in series are overloaded, one Model PAD:70-5, which has been changed over to the constant current mode first, would be supplied with the output voltage of the other inversely.

This would damage series transistors of the former.

To avoid this trouble, a diode is connected between the output terminals of each Model PAD 70-5, as shown in Fig. 3-7.

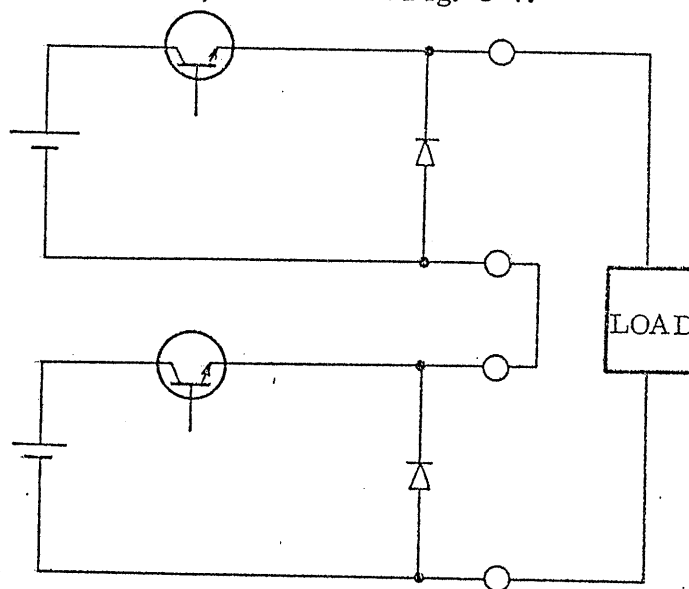

Fig. 3-7

### 3.8 Paralled Connection

When a larger current than 5A is required, connect the output terminals of two Model PAD 70-5 in parallel.

- 1) Set the output voltages of the two Model PAD 70-5 in parallel connection at values as close as possible each other since a setting difference between the two would cause load fluctuation.
- 2) Turn "CURRENT" knobs fully clockwise.
- 3) Connect the output terminals of two Model PAD 70-5 to the load so that their polarity matches.

The grounding polarity of both should also match.

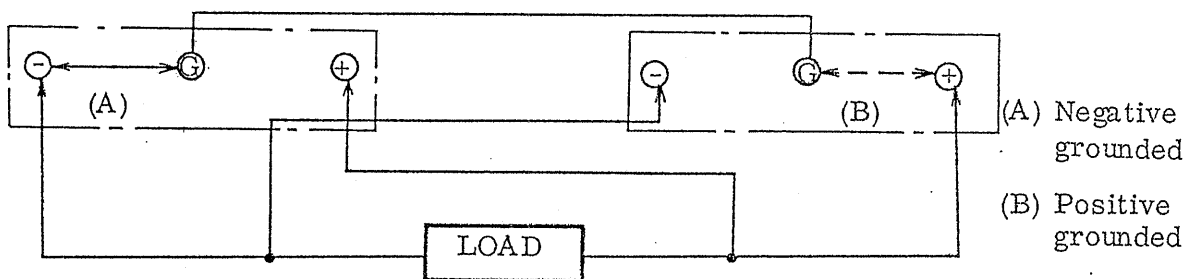

Fig. 3-8 Parallel connection diagram

#### Voltage-current characteristics in parallel connection

As the voltage-current characteristics in parallel connection in Fig. 3-9 show the output voltage in parallel operation remains constant until one Model PAD 70-5 with a higher output voltage is overloaded. When one Model PAD 70-5 is changed over to the constant current mode, the output voltage decreases until it reaches the value preset by the other Model PAD 70-5 whose output terminals are changed over from an inverse voltage condition to a normal one, causing the constant voltage mode. Thus, load fluctuation causes the output voltage to fluctuate by the preset output voltage difference  $\Delta V$  between the two units, and ripple characteristics are reduced.



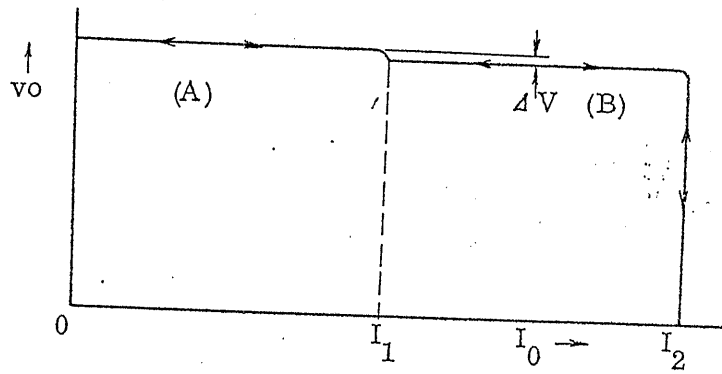

Fig. 3-9 Characteristics diagram

### 3.9 One-control parallel operation

When a larger current than 5A is required, one-control parallel operation of two Model PAD 70-5 is preferable since the characteristics are improved largely, as compared with those in parallel connection.

In one-control parallel operation, one of the Model PAD 70-5 operates as the master unit, by which the output voltage is adjusted, and the other as the slave whose output voltage is controlled by the master unit.

- 1) Connect the terminals on the rear panel of the master to the slave and the load as shown in Fig. 3-10.
- 2) Pick up the output at the output terminals on the rear panel of the master. When turning on the power switches of the master and slave, start with the master. When turning them off, start with the slave.

Note 1 Picking up the output on the output terminals on the front panel of the master causes load regulation to be deteriorated somewhat, and current unbalance occurs between the master and slave.

Note 2 To prevent load regulation from increase, use the sampling terminals. (Connection is showed Fig. 3-11)

Note 3 Turn "VOLTAGE, CURRENT" knob of the slave fully clockwise.

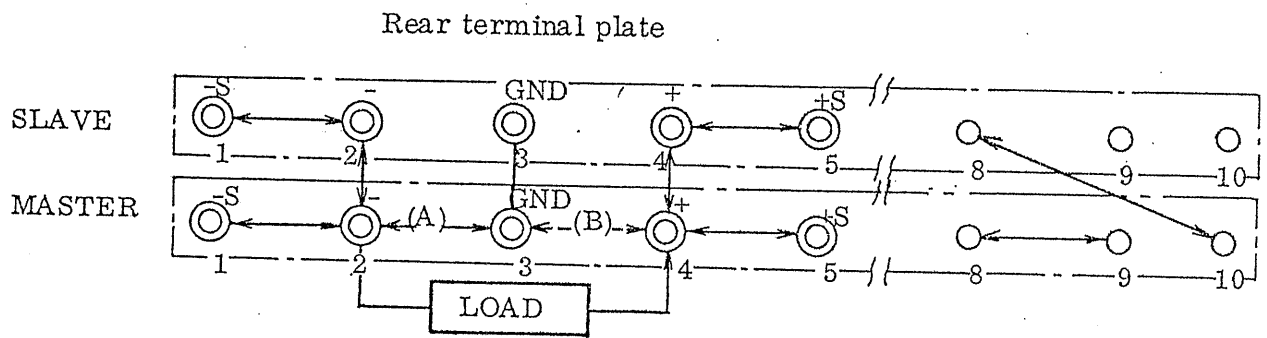

Fig. 3-10 One-control parallel operation master, slave, load

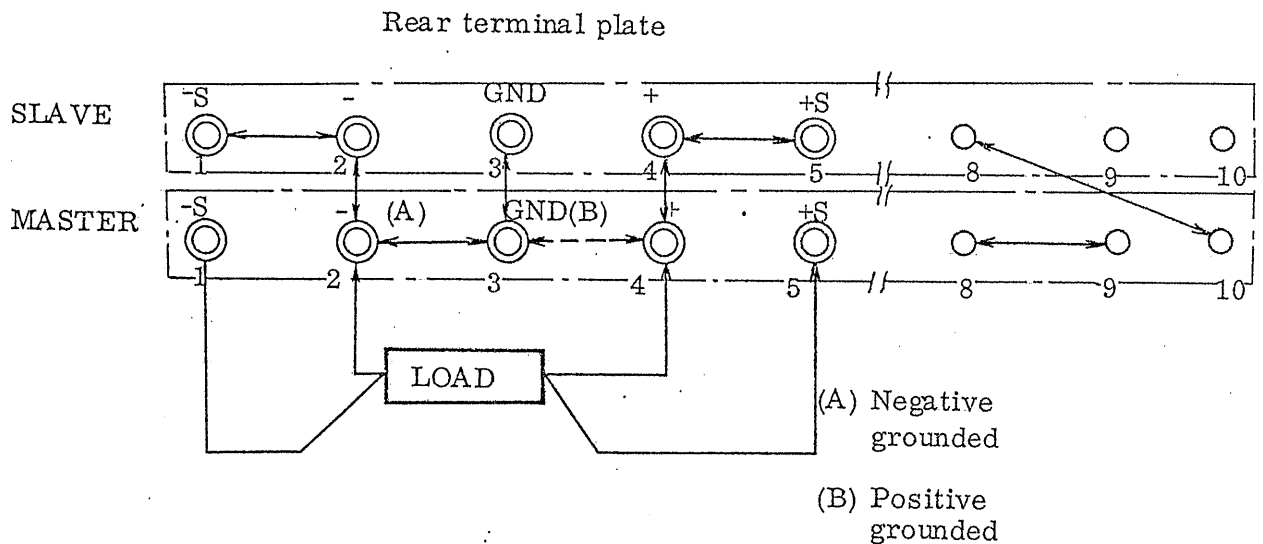

Fig. 3-11 Using sampling terminal in one-control parallel operation

### 3.10 Remote control

To vary output voltage by remote control, improve efficiency in varying output voltage and obtain the preset output voltages simply by operation of switches or others, use the remote control terminals on the rear panel.

- 1) Turn off power switch and remove jumpers from terminals 6 and 7 on the rear panel.
- 2) Provide a suitable variable element between 6 and -S.

Note Variable element will be described in detail later.

3) Turn on power switch and then output voltage will vary according to the characteristic of the variable element connected.

Note If the line connected to variable element is open, output voltage cannot be controlled, and excessive output voltage is detected. Make the connection with power switched off.

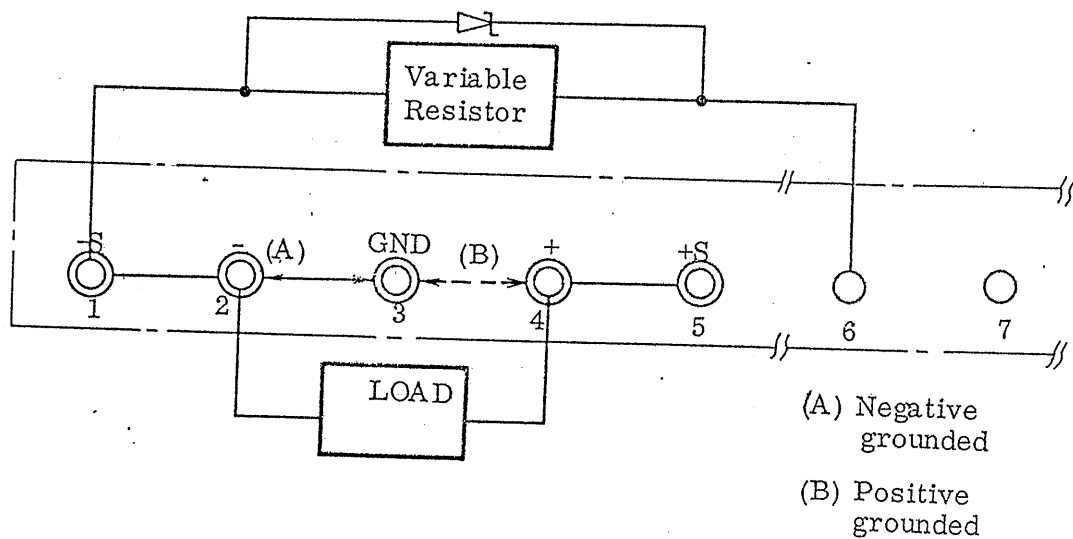

Fig. 3-12

3.10-1 To vary output voltage by remote control.

Output voltage varies at a rate of approximately 0.7V/k ohms with reference to the resistance of the resistor connected. Therefore,

$$\text{Output voltage } V_o(\text{V}) = \text{Voltage variation rate } 0.7 \text{ V/k ohms} \times R_r [\text{k ohms}]$$

where voltage variation rate indicates voltage change for each 1 k ohms, and  $R_r$  the resistance [k ohms] for remote control.

If no suitable resistor is available and output  $V_o$  may exceed the rated output or it is desired to fix voltage at a certain level, output voltage can be limited by connecting zener diode with a small leakage current to the resistor. (See Fig. 3-12)

Note Use a wire wound type variable resistor with a low temperature coefficient or a metal-film one, and the power rating of such a resistor must be at least 0.5W more over. Otherwise, the temperature drift of output voltage may deteriorate.

Note PAD 70-5 can operate steadily if the external lines connected are limited to approximately 2m. If longer lines are used, output voltage may become unstable.

3-10-2 To improve efficiency in varying output voltage (to finely adjust voltage).

As already mentioned, output voltage is proportional to the external resistance.

Letting  $V_{res}$  stand for the required efficiency, the efficiency of the resistor can be formulated as follows.

$$R_{res} = \frac{V_{res}}{\text{Voltage variation rate } 0.7 \text{ V/k ohms}} \quad [\text{k ohms}]$$

### 3.11 Internal temperature detector circuit

When the internal temperature exceeds rated the built-in circuit automatically shuts off the output circuit.

Therefore, if this instrument is used in a place where the ambient temperature is over 40°C, or used by mounting it on another instrument, the entire output or current may not be obtained. Since this circuit is restored to its original condition soon after the internal temperature lowers below the specific value, turn off the power switch, and cool the instrument if the output cannot be obtained as specified while the circuits operate normally.

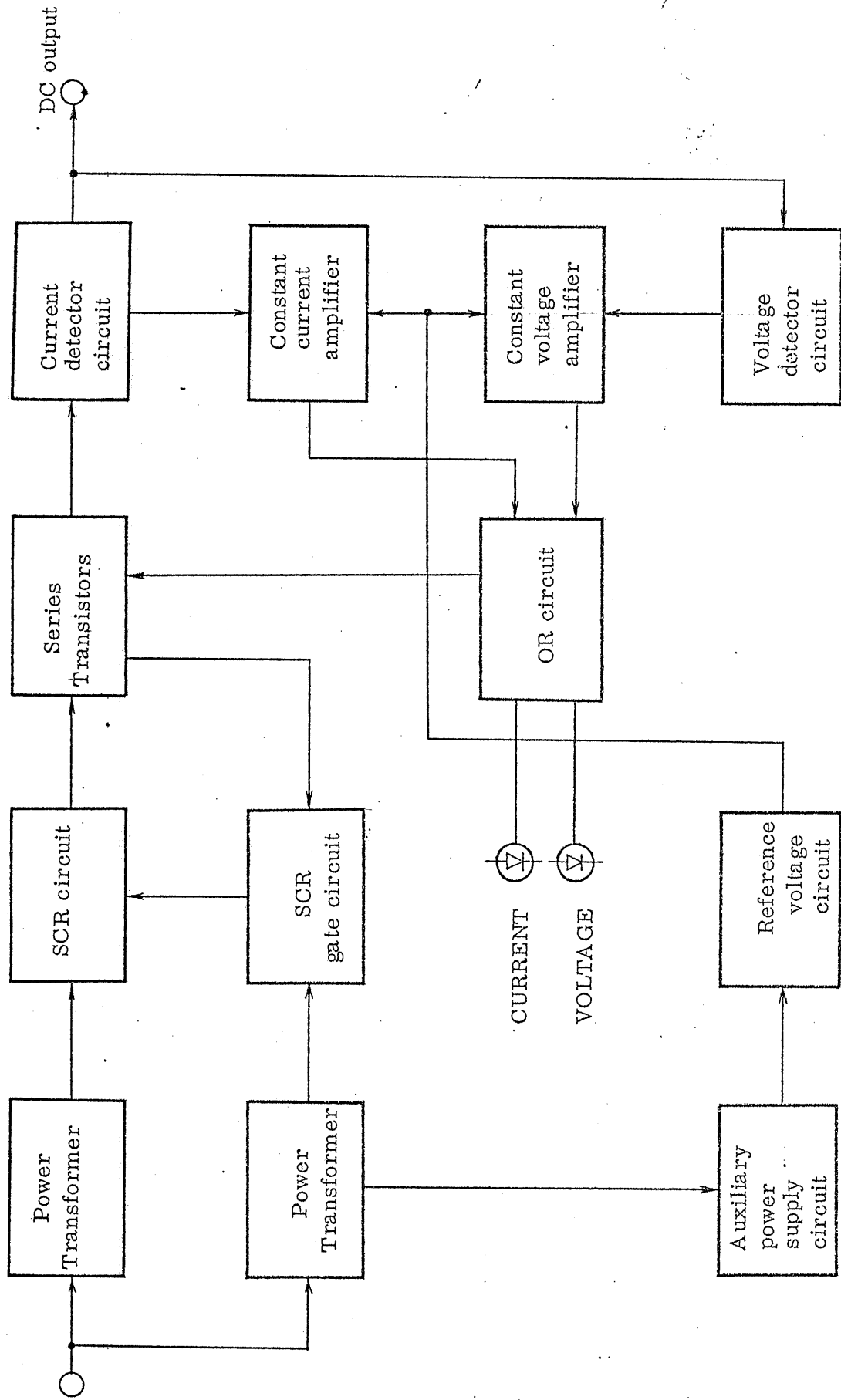

Fig. 4-1 Block diagram